

HYPHERPRO

STEERING DAMPER MOUNTING KIT

for

Yamaha MT-09 Model 2021->

MK-YA09-B001 PART LIST

SD stroke 68 REVERSED	1	M6x30	1
Damper clamp [MP-DB018235]	1	M8x25 Button head	1
O-Ring	2	M8x30 Button head	1
Fork clamp ϕ 52 [MP-FC0520]	1	M8x50 Button head	1
Frame bracket [MP-FRMK52-1]	1	Washer M8 ϕ 16	2
St. head clamp [MP-FRMK52-2&3]	1	-	-
Support bracket [MP-FRMK52-4]	1	-	-
Spacer [MP-SP081505]	1	-	-

ALL IDEAS, DESIGNS ARRANGEMENTS AND PLANS INDICATED OR REPRESENTED BY THIS DRAWING ARE OWNED BY HYPERPRO AND WERE CREATED, EVOLVED AND DEVELOPED FOR USE ON AND IN CONNECTION WITH THE SPECIFIC PROJECT. NONE SUCH IDEAS, DESIGNS, ARRANGEMENTS OR PLANS SHALL BE USED BY OR DISCLOSED TO ANY PERSON, FIRM OR CORPORATION FOR ANY PURPOSE WHATSOEVER WITHOUT THE WRITTEN PERMISSION OF HYPERPRO.

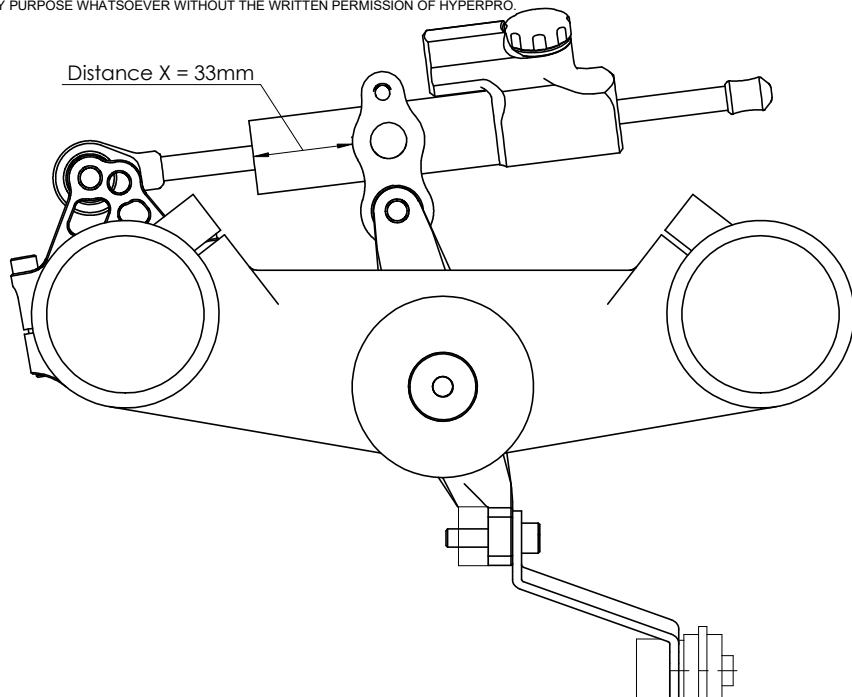

Step 1: relocate the horn and remove the horn bracket

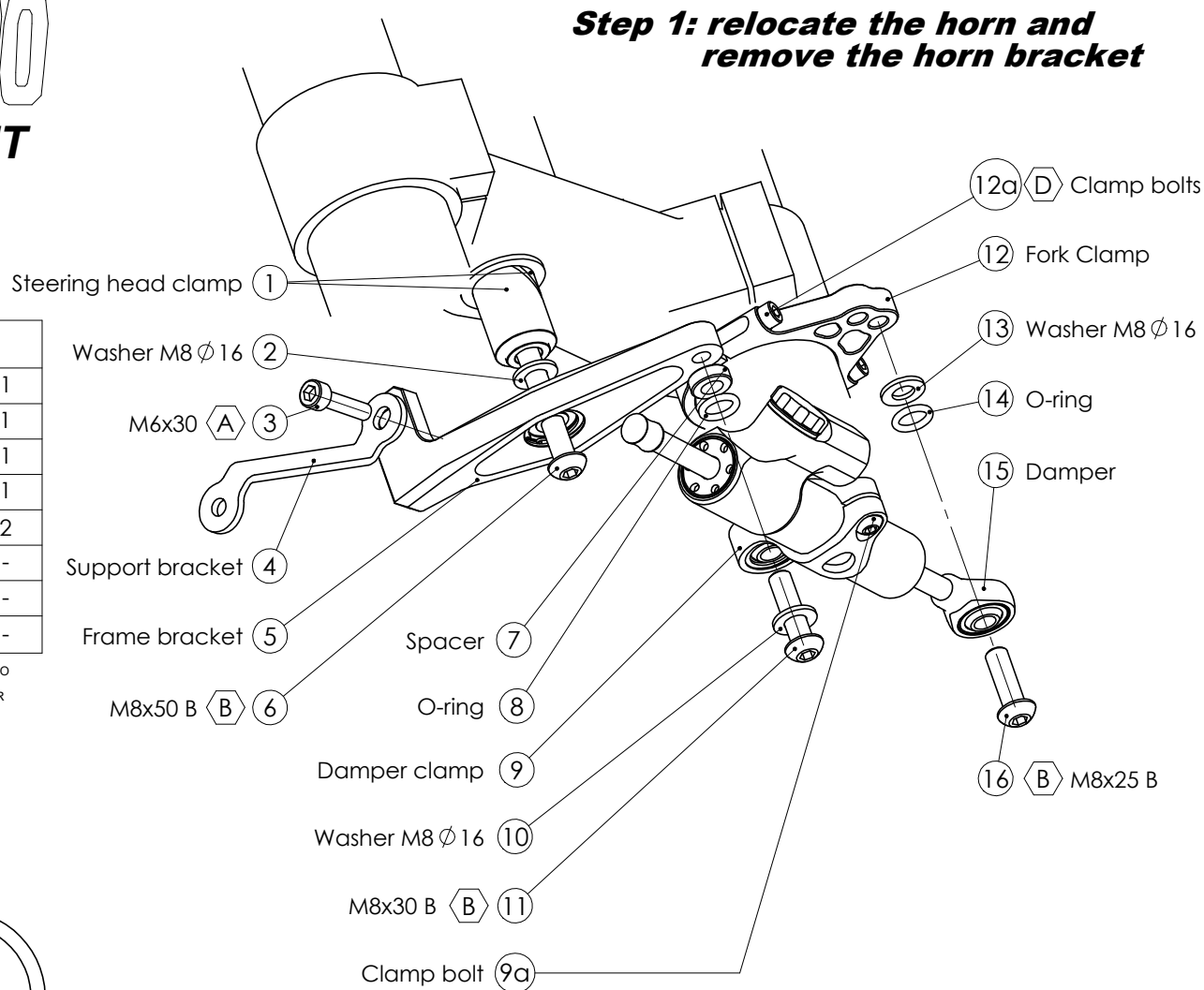

* TORQUES

A: 5-9Nm / 44-80Lbs.In / 4.0-6.4Lbs.Ft
 B: 14-17Nm / 124-150Lbs.In / 10.3-12.5Lbs.Ft
 C: 6Nm / 53Lbs.In / 4.4Lbs.Ft

D: 8Nm / 70Lbs.In / 5.9Lbs.Ft
 E: 55Nm / 486Lbs.In / 40Lbs.Ft
 F: Factory torque (see owners manual)

HYPERPRO

STEERING DAMPER MOUNTING KIT

for

Yamaha MT-09 Model 2021->

MK-YA09-B001 INSTALLATION INSTRUCTIONS

In general:

HYPERPRO can not be held responsible in any way for any form of physical, material, financial or other damage arising from use, assembly or overhaul of HYPERPRO products. HYPERPRO reserves the right to make changes without prior notice.

This product is ONLY TO BE INSTALLED BY A PROFESSIONAL MECHANIC.

This product is only to be used for the motorcycle brand, model and year stated specifically on top of the pages of this manual.

DO NOT attempt to install this product on motorcycles from any different brand, model and/or year than stated on the pages of this manual.

DO NOT use this kit for cars, boats, jet skis, snowmobiles, ATV's, aircraft, hovercrafts or any other vehicle and/or purpose.

HYPERPRO steering dampers are FOR RACE USE ONLY, NOT FOR HIGHWAY USE!

Before installation:

- Please read the entire manual carefully before starting the installation!
- Check if you have all the tools required. Good tools are a must.
- Protect your bike at the most important places in and around the work area (e.g. tank, fairing, frame, etc.), with a blanket, towel or similar.

During installation:

- Check all operations and parts carefully before, during and after performing each step.
- Clean all surfaces that are required for fitting parts together or for applying self adhesives or loctite, thoroughly with contact cleaner or another degreaser, unless otherwise stated.
- Be careful not to damage or scratch any part of your bike.
- ALWAYS work relaxed and concentrated!! It is very easy to damage something or make a mistake.

After installation:

- Check and make sure that there is no contact between any part of the steering damper kit and any part of the motorcycle. The kit should not hit anything. Steering movement should not be limited by the steering damper. If the steering movement is limited, adjust the position of the tube in the clamp until steering movement is normal again. Do not forget to tighten the clamp bolt again!
- ALWAYS check the steering movement and feeling before each ride !
- FIRST RIDES: Start with the damper turned fully open (turn adjuster knob fully counter clockwise). Start adjusting in between rides with steps of MAX. 2 CLICKS (0.25 TURN) EACH TIME, until the damper is working satisfactory for your riding style.
- NEVER USE MAXIMUM SETTING, ALWAYS OPEN AT LEAST 2 CLICKS (0.25 TURN).

- WARNING ! DAMPER HAS AN ACTIVE / SPEEDSENSITIVE DAMPING SYSTEM;
 - Steering with NORMAL MOVEMENT should be FREE !!
 - Steering with FAST MOVEMENT should be CONTROLLED BY DAMPER !!
- HYPERPRO uses a special seal to reduce friction. The seal uses an oil film to work properly. It is normal that some oil can appear on the pistonrod.
- Damper works with oil: DAMPING CAN BE HARDER AT LOWER TEMPERATURES!

Step 1: relocate the horn

Disassemble the horn + plate from the mounting bracket by removing the M6 bolt.
Remove the mounting bracket from behind the lower headlight bracket.
Unclip the horn cable from the headlamp housing.

Install the horn to the upper left headlight mount, using the original bolt (see picture).
Make sure that the horn+plate do not touch anything.

Step 2: install the frame bracket

Install the frame bracket using:

- Steering head clamp (1)
- Washer M8 \varnothing 16 (2)
- Bolt M6x30 (3)
- Support bracket (4)
- Frame bracket (5)
- Bolt M8x50 Button head (6)

Remove the bolt from the cable bracket directly behind the steering head.

Remove the bolt from the right hand radiator top mount.

Remove the rubber cap from the bottom of the steering head. Make sure the steering stem is clean and shove the steering head clamp parts (1) inside with the tapered end first.

Mount the frame bracket (5) to the clamp (1) with a washer (2) and the M8x50 bolt (6).

The distance between the bottom of the steering stem and the top of the bracket should be \pm 3mm, (so the bolt (3) can easily be fitted). Tighten bolt (6) to a torque of approx. 14-17Nm/124-150Lbs.In/10.3-12.5Lbs.Ft.

Mount support bracket (4) to the radiator mount as shown on page 1, use the original M6 bolt. mount the other side on top of frame bracket to the frame using bolt M6x30 (3).

Tighten the M6 bolts to a torque of approx. 5-9Nm/44-80Lbs.In/4.0-6.4Lbs.Ft.

Step 3: install the damper clamp

Install the damper clamp using:

- Damper clamp (9)
- Spacer (7)
- Washer M8 \varnothing 16 (10)
- O-ring (8)
- Bolt M8x30 (11)

Install the damper clamp (9) to the frame bracket (5) using the mounting parts (7) - (11) in the correct order and tighten bolt (11) to a torque of approx. 14-17Nm/124-150Lbs.In/10.3-12.5Lbs.Ft.

Step 4: install the fork clamp

Disassemble the fork clamp (12) and reassemble around the left fork leg, directly under the lower triple clamp. Position and align the clamp as shown in the pictures.

Tighten the clamp bolts (12a) evenly to a torque of approx. 6Nm/53Lbs.In/4.4Lbs.Ft.

Step 5: install the steering damper

Install the steering damper using:

- Washer M8 \varnothing 16 (13)
- 1x O-ring (14)
- Steering damper S68 reversed (15)
- Bolt M8x25 (16)

Ensure that the clamp bolt (12a) of the damper clamp is pointing forward. Shove the damper (14), with the adjuster knob-side first, through the clamp until the ball joint can be fitted to the tank bracket. Use the washer (11), O-ring (12) and M8 bolt (14) to fixate the ball joint to the tank bracket and tighten with a torque of approx. 14-17Nm/124-150Lbs.In/10.3-12.5Lbs.Ft. Position the damper tube until the distance "X" stated on page 1 is reached, then tighten the M6 clamp bolt (15) with a torque of approx. 6Nm/53Lbs.In/4.4Lbs.Ft. Check if the damper is level horizontally and aligned to the bike. Check if the damper does not touch anything (e.g. tank) when steering from left to right. Check if the bike can make it's full steering angle from left to right.

